

5B – for all KSB type series with a standardised seal to EN 12756

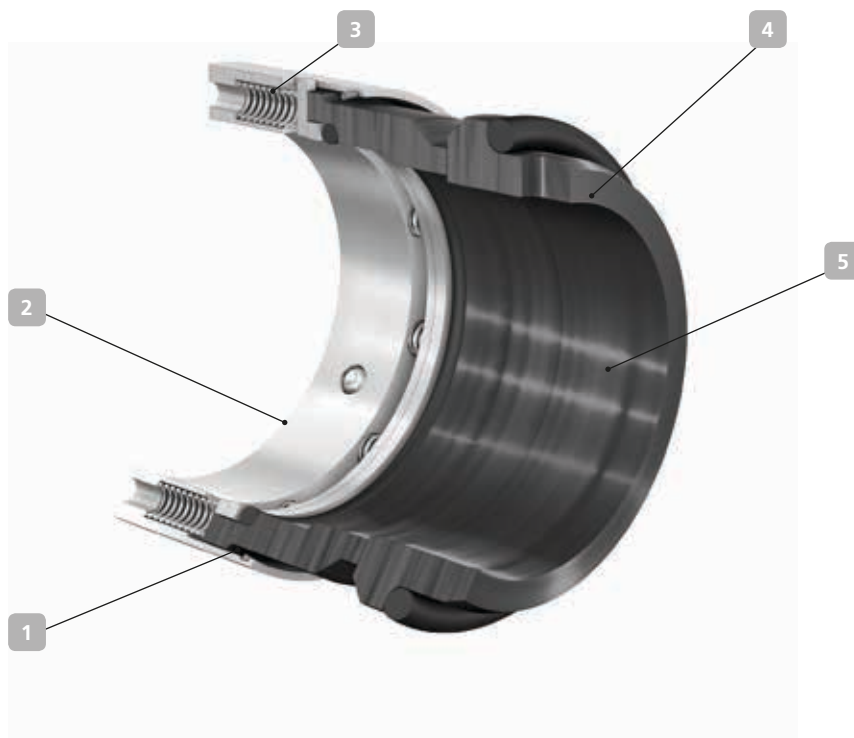

Applications:
universal

1 Easy to install

The single seal features a circlip which holds together the dynamic unit. This makes installation so much easier.

2 Versatile

Also for use with a quench system or as double seal in back-to-back arrangement or tandem arrangement.

3 Universal

The seal is designed for universal use and fits perfectly into standardised installation spaces, e.g. of Multitec and MegaCPK pumps.

4 Dependable

Suitable for all pumps with standardised seals. Many material combinations available.

5 Interchangeable

The seal can replace other seals with standardised installation dimensions such as Burgmann H7N or Crane 58B without any modifications.

Technical description

Design	Single mechanical seal
Type	Dynamic, balanced
Springs	Multi-spring arrangement
Direction of rotation	Bi-directional
Additional information	WRAS drinking water approval

Materials

Primary ring	SiC (Q1) / "B" carbon (B) / "A" carbon (A), tungsten carbide (U)
Mating ring	SiC (Q1) / tungsten carbide (U)
Elastomers	EPDM (E) / FKM (V)
Springs	1.4571 (G) / 2.4610 (M)
Other Components	1.4571 (G)

Technical data

Operating pressure	Up to 25 bar dynamic up to 37.5 bar static
Temperature	-30 °C to 220 °C
Spring travel	+/- 3 mm
Seal size	See standardised seal selection chart on the next page
Business type	Standard (KSB EasySelect)

Higher application limits on request

5B – for all KSB type series with a standardised seal to EN 12756

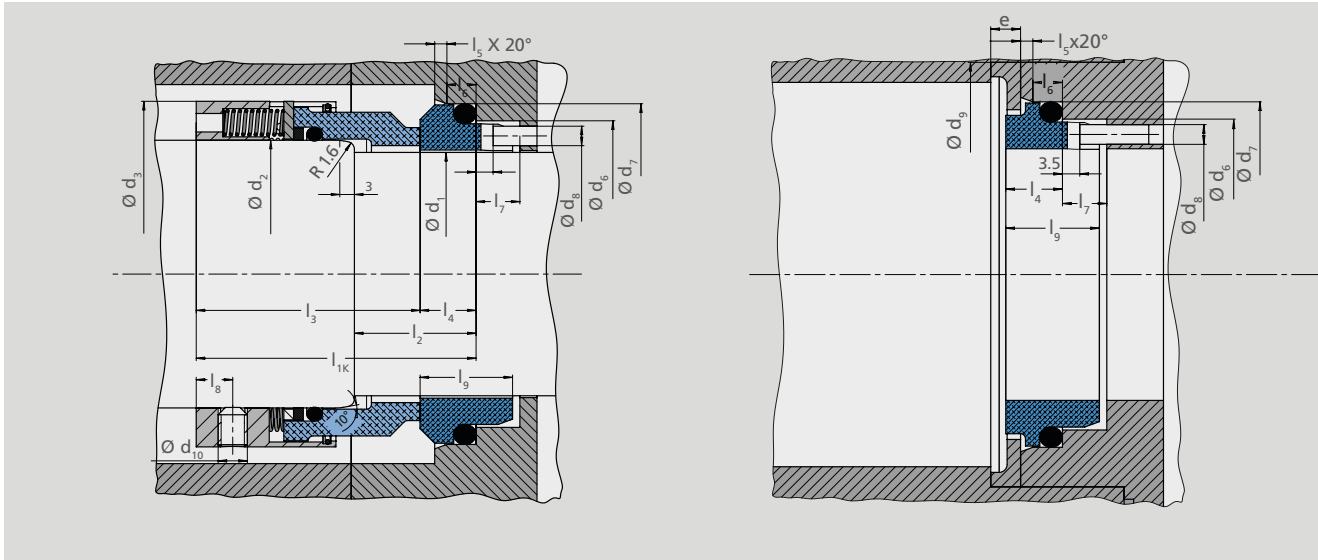

Dimensions for 5B (in mm)

Nominal diameter	d_1	d_2	Maximum $d_3^{1)}$	d_6	d_7	d_8	d_9	d_{10}	e	$l_1 K^{2)}$	l_2	l_3	l_4	l_5	l_6	l_7	l_8	l_9
	h6	h6		H11	H8		H8			± 0.5	± 0.5					$+0.5$		
28	33	47	37	43	3	53	M6x6	4	50	20	40	10	5	6.5	17.5			
30	35	49	39	45		60	M6x6				40	10						
33	38	54	42	48		62	M6x8				40	10						
35	40	56	44	50	4	65	M6x8	52.5	23	40	10	2	6	18.5				
38	43	59	49	56		67	M6x8			41.5	11							
40	45	61	51	58		70	M6x8			41.5	11							
43	48	64	54	61		72	M6x8			41.5	11							
45	50	66	56	63		75	M6x8			41.5	11							
48	53	69	59	66		77	M6x8			41.5	11							
50	55	71	62	70		86	M6x8			46	11.5							
53	58	78	65	73	88	M6x10	46	11.5	6	9	7.5	19						
55	60	80	67	75	91	M6x10	46	11.5										
58	63	83	70	78	4	93	M6x10	62.5	25	51	11.5	2,5	8.5	10	20			
60	65	85	72	80		96	M8x10			51	11.5							
63	68	88	75	83		98	M8x10			51	11.5							
65	70	90	77	85	6	103	M8x10	70	28	51	11.5	3	12	20.5				
70	75	99	83	92		108	M8x12			57.5	12.5							
75	80	104	88	97		120	M8x12			57.5	12.5							
80	85	109	95	105		125	M8x12			57	13							
85	90	114	100	110		130	M8x12			62	13				7			
90	95	119	105	115		135	M8x12			62	13							
95	100	124	110	120		140	M8x12			62	13				75	28	3	12
100	105	129	115	125	145	M8x12	62	13										

¹⁾ To determine the safety distance between rotating and stationary components the dimensions d_3 are recommended as maximum dimensions.

²⁾ The mechanical seal manufacturer may supply a mechanical seal shorter than l_1 . Any differences in length should be compensated by means of a spacer which should also be supplied by the manufacturer of the mechanical seal.

The blue marking indicates that the KSB seal is on stock.